

**Errata for the 8th & 9th Printings of
"Understanding Digital Signal Processing, 2/E",**
by Richard Lyons

I beg your pardon for the typographical errors in the book.
(I arranged to have roughly 80% of the following "typos"
corrected in earlier Printings of the book but, sadly, some sort
of strange mistake occurred at the publisher that reintroduced
these errors in the 8th & 9th Printings of the book! ☹)
It will not take long to make these corrections. I promise.
-Rick Lyons-

Page 7: In the third line below Eq. (1-7), the text:

"... indicate that $X_{\text{sum}}(n)$ has a frequency ..."

The uppercase "X" should be lowercase "x" as:

"... indicate that $x_{\text{sum}}(n)$ has a frequency ..."

[Found by Angela Livingstone, 3/30/08; [Production Error]

Page 31:

In the 3rd line above EQ. (2-6), in the text:

"... and negative bands, P and Q, just butt up ..."

the letters "P" & "Q" should be swapped making it:

"... and negative bands, **Q** and **P**, just butt up ..."

[Found by Jimmy Ceilidh [12/29/04].][Author Error]

Page 34: In the 5th line down, the text:

"... where spectral replications do not butt up against each
other except at zero Hz."

is confusing. Please edit it as follows:

"... where spectral replications ~~do not~~ butt up against each
other ~~except~~ at zero Hz."

Page 37: The " f_s " labels, within the arrows, at the very
bottom of Figure 2-13 should be " $f_s/2$ ".

[Found by Author [6/20/06].][Author Error]

Page 38: In the fifth line up from the bottom of the page,
the text:

"... where m_{odd} is an odd integer[14]."

should be changed to:

"... where m_{odd} is an odd integer greater than one[14]."

[Found by Jim Murphy [9/14/05] & Justin Reeves [6/20/06].][Author Error]

Page 40: In the 2nd line below Eq. (2-14), the text:

" $m = 2$ provide an optimum ..."

should be changed to:

" $m_{\text{even}} = 2$ provide an optimum ..."

[Found by Justin Reeves, 6/20/06.][Author Error]

Page 42: In the middle of Table 2-2, on the right side, the text:

" m_{odd} is any positive odd integer ..."

should be changed to:

" m_{odd} is an odd integer greater than one ..."

[Found by Justin Reeves, 6/20/06.][Author Error]

Page 48: The incorrect letter "v" in the third line of Eq. (3-4d) should be replaced with a "." multiplication symbol.

[Found by Uday Padmanabhan, 11/19/08.][Author Error]

Page 62: The second part of equation (3-18') printed as:

$$x(n) = \frac{1}{\sqrt{N}} \sum_{n=0}^{N-1} X'(m) e^{j2\pi nm/N} \quad (3-18')$$

should have the lower limit of the summation changed to "m" instead of "n", as :

$$x(n) = \frac{1}{\sqrt{N}} \sum_{m=0}^{N-1} X'(m) e^{j2\pi nm/N} \quad (3-18')$$

[Found by Larry Ong, 2/19/08.][Author Error]

Page 62: On the sixth line of Section 3.5, the text:

"... answer is not "1."

should be replaced with

"... answer is not 1 kHz."

Page 77: For **both** Eq. (3-29) and Eq. (3-30), the "-1" characters should be deleted from the denominator of the cosine arguments. The cosine argument, in both equations, should be:

"... $\cos(2\pi n/N)$,"

[Found by Author, 10/26/07.][Author Error]

Page 93: The last term in Equ. 3-37 has a missing minus sign in its exponent. The last term should be:

$$\dots + e^{-jq(K-1)}].$$

[Found by Stan Moore, 3/19/12.][Production Error]

Page 122: The caption to Figure 3-47 was printed as:

"DTFT magnitude $|X_o(w)|$ "

The "w" should be the Greek " ω " character, making the caption:

"DTFT magnitude $|X_o(\omega)|$ "

Page 135: On the 3rd line from the bottom, the "1" in:

$$"e^{-j\pi} = 1"$$

should be a minus 1 as

$$"e^{-j\pi} = -1"$$

[Found by Antoine Trux, 1/2/07.][Author Error]

Page 143: In Figure 4-10, in the middle stage there is the number 4 on the 1st and 2nd (counting down from the top) southeast-pointing arrows. Those 4s should not be there. The 4s should be on the 3rd and 4th southeast-pointing arrows of the middle stage as shown below.

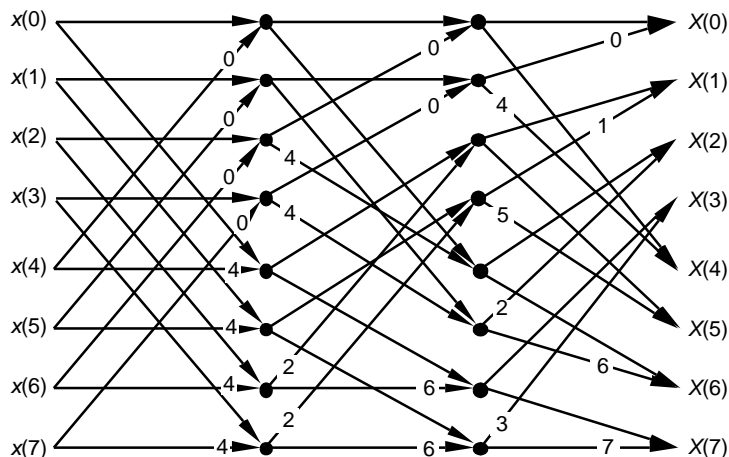

[Found by Antoine Trux, 1/2/07.][Author Error]

Page 241: Near the left side of Figure 6-21(a), the "Imag z" axis label is missing.

[Found by Nikhil Sarma, 4/28/04.][Author Error]

Page 244: The normalized-frequency labeling (radians/sample) on the frequency axis of Figures 6-24(b) and 6-24(c) should be changed as:

-2π changed to -4π

$-\pi$ changed to -2π
 π changed to 2π
 2π changed to 4π

[Found by Author, 10/17/08.] [Author Error]

Page 257: In the eleventh line below Eq. (6-87)

"... Figure 6-21(b). Knowing that ..."

should be changed to:

"... Figure 6-**22**(b). Knowing that ..."

[Found by Yancen Li (7/14/14)]; [Author Error]

Page 264: In the 6th line of the first full paragraph, the text:

"...squeezed in toward zero Hz."

should be:

"...squeezed in toward $f_s/2$ Hz."

[Found by VV (vanamali), 3/12/09.] [Author Error]

Page 264: In the next to the last line of the first full paragraph there's a missing "|" vertical bar character indicating "magnitude". The text:

"...in $|H_d(f_d)-...$ "

should be:

"...in $|H_d(f_d)|-...$ "

[Found by Author, 7/14/05.] [Author Error]

Page 265: In the first and third lines of the caption to Figure 6-32, the subscripted "c" in " f_c " should be an "a", as " f_a ".

In the third line of the caption, the subscripted "c" in " H_c " should be an "a", as " H_a ".

[Found by Author, 7/14/05.] [Author Error]

Page 267: There is a missing " $x(n)$ " factor in Equation (6-114), the first part of that equation should be:

$$y(n) = 0.20482712 \cdot \mathbf{x(n)} + 0.40965424 \cdot x(n-1) + \dots$$

[Found by Kendall Castor-Perry, 5/3/09.] [Author Error]

Page 286: The feedback coefficient of the resonator in Figure 7-3, printed as:

$$e^{j\Omega T}$$

it should be changed to:

$$e^{j\omega t}$$

[Found by Author, 7/14/09.] [Production Error]

Page 339: In Figure 8-3, the last fraction on the right of the second line down was printed as:

$$\frac{(jf)^6}{6!}$$

The letter "f" should be changed to the Greek letter ϕ , as:

$$\frac{(j\phi)^6}{6!}$$

[Found by Prof. Kai-Kuang Ma, 2/28/05.] [Author Error]

Page 345: On the right side of Figure 8-8 the term $e^{j2\pi f_0 t}$ should be divided by two, making it

$$e^{j2\pi f_0 t}/2.$$

[Found by John Littig, 9/24/07.] [Author Error]

Page 353: In the sentence just before Eq. (8-17), the described notion of orthogonality of $i(n)$ and $q(n)$ is only conditionally true. Because this orthogonality topic was not described in sufficient detail, I suggest you strike out both the sentence just before Eq. (8-17) as well as Eq. (8-17) itself.

[Found by Ken Walsh, 5/9/06.] [Author Error]

Page 373: Item# 3 is not worded properly. In the second sentence printed as:

"We can widen (somewhat) and reduce the ..."

Please replace the above "(somewhat)" with:

"We can widen **the passband** and reduce the ..."

[Found by Author, 5/22/04.] [Author Error]

Page 389: In the seventh line of the second paragraph, the text is printed as:

"The lower the attenuation, the ...".

Please change the word "lower" to "greater" so that the text reads:

"The **greater** the attenuation, the ...".

[Found by Mark Kolber, 1/29/08.] [Author Error]

Page 399: Equation (10-8) was printed as:

$$Y(z) = \frac{1}{D} [X(z) + X(z)z^{-1} + X(z)z^{-2} + \dots + X(z)z^{-D+1}] \quad (10-8)$$

The $X(n)$ terms should all be $X(z)$, so Eq. (10-8) should be

$$Y(z) = \frac{1}{D} [X(z) + X(z)z^{-1} + X(z)z^{-2} + \dots + X(z)z^{-D+1}] \quad (10-8)$$

[Found by Gurpal Gill, 4/7/05.] [Author Error]

Page 430, fourth line down in 1st paragraph of Section 11.4:

The words printed as:

"... (N-1)-tap FIR filter ..."

Should be changed to read as:

"... N-tap FIR filter ..."

[Found by Author, 12/18/04.] [Author Error]

Page 430: last line on the page: The words printed as:

"... through $b(N)$ coefficient ..."

Should be changed to read as:

"... through $b(N-1)$ coefficient ..."

[Found by Author, 12/18/04.] [Author Error]

Page 478: in the fifth line down, delete the text:

"...followed by another K delay..."

In Figure 13-6(c) the final z^{-K} delay block should be deleted making that figure look as follows:

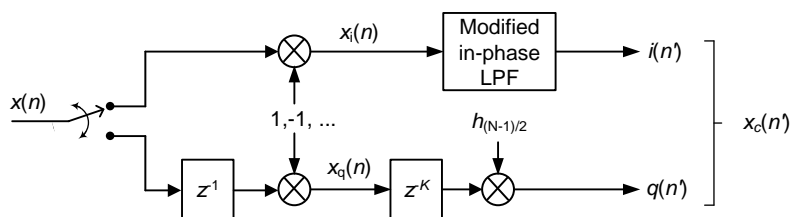

[Found by Brian Frantz, 8/8/17.] [Author Error]

Page 479: In Figure 13-6(b) the superscripted "-2" characters shown by the large arrows below:

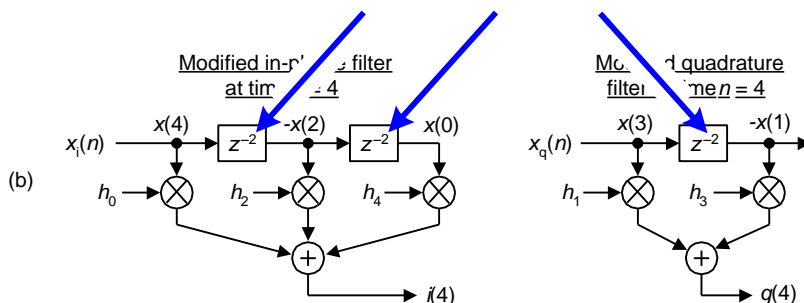

Should be changed from "-2" to "-1" making Figure 13-6(b) become:

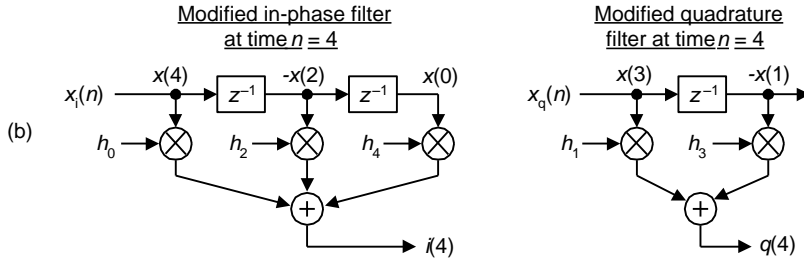

[Found by Damon Bradley, 10/1/09.] [Author Error]

Page 484: Equation (13-10) has suffered a series of "foul-ups" in different Printings of the book. Eq. (13-10) should be:

$$W(m) = \sum_{n=0}^{N-1} \alpha e^{-j2\pi nm/N} - \frac{\beta}{2} \sum_{n=0}^{N-1} e^{j2\pi n/N} e^{-j2\pi nm/N} - \frac{\beta}{2} \sum_{n=0}^{N-1} e^{-j2\pi n/N} e^{-j2\pi nm/N}$$

$$= \alpha \sum_{n=0}^{N-1} e^{-j2\pi nm/N} - \frac{\beta}{2} \sum_{n=0}^{N-1} e^{j2\pi n(m-1)/N} - \frac{\beta}{2} \sum_{n=0}^{N-1} e^{-j2\pi n(m+1)/N}. \quad (13-10)$$

[Found by Author, 3/22/04.] [Author Error]

Page 488: Equation (13-18) has minus signs where equal signs should be. Equation (13-18) should be:

$$\begin{aligned} x(0) &= a(0) + jb(0) \\ x(1) &= a(1) + jb(1) \\ x(2) &= a(2) + jb(2) \\ &\vdots \\ &\vdots \\ x(N-1) &= a(N-1) + jb(N-1) \end{aligned} \quad (13-18)$$

[Found by Author [1/11/07].] [Production Error. Wierd. This error was NOT in the 1st Edition!]

Page 489: In the 3rd line below Eq. (13-22) change the text from:

"... in Eq. (13-40) , ...
to:
"... in Eq. (13-20) , ...

[Found by Antoine Trux, 1/11/07.] [Author Error]

Page 496: In the 6th and 7th lines below Eq. (13-40) change the text from:

"... real, $X_a(N)$ through $X_a(2N-1)$ are merely the complex conjugates of their $X_a(0)$ through $X_a(N-1)$ counterparts ..."

to:

"... real, $X_a(N+1)$ through $X_a(2N-1)$ are merely the

complex conjugates of their $X_a(\mathbf{N-1})$ through $X_a(\mathbf{1})$ counterparts ..."

[Found by Antoine Trux, 1/11/07.][Author Error]

I (the author) suggest you write the following in the book's margin:

$$"X_{a,\text{real}}(\mathbf{N}) = X_r(0) - X_i(0)"$$

$$"X_{a,\text{imag}}(\mathbf{N}) = 0"$$

Page 518: For more accurate results, the "12/M" factor at the beginning of Eq. (13-70) should be changed to $\sqrt{12/M}$. Thus Eq. (13-70) should be:

$$y_{\text{desired}}(n) = \sqrt{\frac{12}{M}} \cdot \sigma' \cdot \left[\left(\sum_{k=1}^M x_k(n) \right) - \frac{M}{2} \right] + \mu'. \quad (13-70)$$

[Found by Bharat Pathak, 7/13/07.][Author Error]

Page 519: Under Section 13.13, Sharpened FIR Filters, the second sentence in the opening paragraph is printed as:

"Actually, we can a filter's double stopband ..."

Please move the word "double" in front of the "a", resulting in:

"Actually, we can double a filter's stopband ..."

[Found by Chris Frailey, 12/8/04.][Author Error]

Page 548: 4th line below Eq. (13-107), change the text:

"... 0.26° using ..."

to

"... 0.28° using ...".

For preciseness, you might note on Figure 13-59 that the error is -0.28° at True $\theta = -45^\circ$, and the error is $+0.28^\circ$ at True $\theta = +45^\circ$, as shown in the following figure.

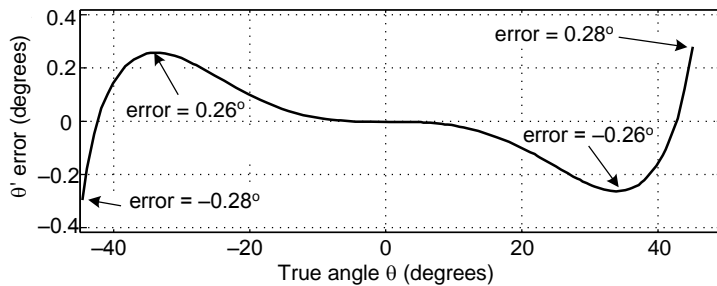

[Found by Chris Zarowski, 4/27/06.][Author Error]

Page 549: 4th line below Eq. (13-109'), change the text:

"... error is 0.26° for ..."

to

"...error is 0.28° for ...".

[Found by Chris Zarowski, 4/27/06.][Author Error]

Page 560: In Figure 13-70(b), on the right side in the "Section 3, r = 1" part of the figure, there should be three stages of delay lines instead of only two stages as shown in the figure. That "Section 3, r = 1" part of the figure should look like the following:

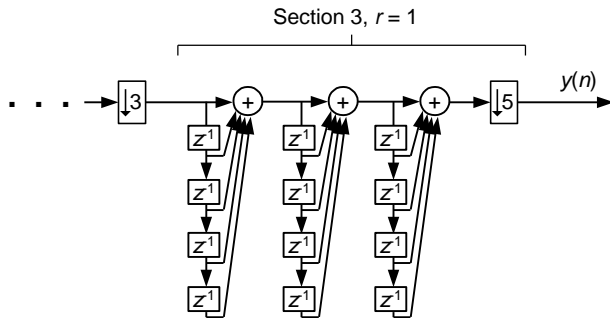

[Found by Mike Totham, 8/31/07.][Author Error]

Page 561: Equation (13-123) has a missing 1/N scale factor in front of the summation. That equation should be:

$$M(q) = \frac{1}{N} \sum_{k=qN}^{(q+1)N-1} x(n) \quad (13-123)$$

[Found by Author, 8/24/08.][Production Error]

Page 569: In the right $X_{int}(m)$ column of Table 13-8, the underline character associated with row $m = 9$ should be a zero "0" value as follows:

m	$X_{int}(m)$
...	...
9	0
...	...

[Found by Author, 3/21/09.][Production Error]

Page 574: In Figure 13-77(a), the "log(R)" factor applied to the adder should be two times the log of R as:

$$2\log(R).$$

[Found by Mark Borgerding, 6/8/05.][Author Error]

Page 575: (At the time of the fifth printing:)

The two labels in Figure 13-78(c) were strangely messed up during the typesetting process. The

$$\alpha = 0.7 \quad \text{and the} \quad \alpha = 0.09$$

labels above the graphs should be changed to

$$\alpha = 0.2 \quad \text{and the} \quad \alpha = 0.05$$

The bottom line in the figure caption is printed as:

"... (c) $E(n)$ for $\alpha = 0.7$ and $\alpha = 0.9$."

That caption text should be changed to:

"... (c) $E(n)$ for $\alpha = 0.2$ and $\alpha = 0.05$."

[Found by Author, 3/24/05.][Production Error]

Page 607: Two corrections: In the second line of Eq. (D-7), the term:

"... $-\cos(\omega t)$] ...

should be:

"... $-\cos(2\omega t)$] ...

In the third line of Eq. (D-7), the term:

"... $-\frac{1}{2}(\sin(\omega t))$..."

should be:

"... $-\frac{1}{4}(\sin(2\omega t))$..."

[Found by Julian Vrbancich, 10/23/12; [Author Error]

Page 610: The final ratio at the end of Eq. (D-12) **MAY** be printed as:

$$\frac{(b-a)^2}{12}.$$

Make sure the numerator looks like (with a PLUS sign):

$$\frac{(b+a)^2}{12}.$$

[Found by Author, 1/15/05.][Author Error]

Page 614: In the sentence just following Eq. (E-2), there is a missing " P_1/P_2 " ratio. That sentence should read as:

"The logarithmic function $10 \cdot \log_{10}(P_1/P_2)$, plotted in ..."

[Found by Nikhil Sarma, 5/18/05.] [Author Error]

Page 623: Under the "Chebyshev Function": the fifth line down is printed as:

"...ripples in the passband and flat passbands..."

It should be printed as:

"...ripples in the passband and a flat **stopband...**"

[Found by Mike Beliard, 1/29/05.][Author Error]

Below are corrections to an *unexplainable* (!!)
number of errors in the Index. (No one that I spoke
to at the publisher's seems to know how this happened.)
Although some people do not think these
corrections are important, I do because the
Index is a VERY important part of a book. On
behalf of my publisher, I beg your pardon for
the following errors.

[-Rick-]

Page 657, Right Column:

The top-level Index entry "Averaging" is missing.
The following lines:

Automatic gain control (AGC), 548, 571
block, 561
coherent, 412
...

should be:

Automatic gain control (AGC), 548, 571
Averaging
block, 561
coherent, 412
...

Page 657, Right Column:

In the following lines:

Averaging
...
...
moving, 398

the page numbers 152, 430, & 578 should be added making the line:

Averaging
...
...
moving, **152, 398, 430, 578**

Page 659, Left Column:

Under the Index entry:

Discrete-time Fourier transform (DFT)
define, 88
an example, 121

the correct acronym spelling and page number should be

Discrete-time Fourier transform (**DTFT**)
define, **87**
an example, 121

Page 660, Left Column:

In the following lines:

```
Filtering/filters (cont.)
...
...
moving average, 152, 398
```

the page numbers 430 & 578 should be added making the line:

```
Filtering/filters (cont.)
...
...
moving average, 152, 398, 430, 578
```

Page 660, Left Column:

There is a missing Index entry. The lines originally printed as:

```
Filtering/filters (cont.)
...
...
prototype, 243
recursive, 242
```

should have the additional Index entry of

```
Filtering/filters (cont.)
...
...
prototype, 243
quadrature filter, 629
recursive, 242
```

Page 660, Left Column:

There is a missing page number. The line originally printed as:

```
Filtering/filters (cont.)
...
...
transposed structure, 241
```

should have the additional 558 page number included

```
Filtering/filters (cont.)
...
...
transposed structure, 241, 558
```

Page 662, Left Column:

Under the Index entry;

```
L'Hospital's rule, 95
```

the correct spelling (no "s") and a missing page number are

Page 663, Left Column:

There is a missing page number. The line originally printed as:

Passband ripple, 186, 629

should have the additional page number of

Passband ripple, 186, **275**, 629

Page 663, Left Column:

In the following line:

Quadratic factorization formula, 224

add the following 240 page number making the line:

Quadratic factorization formula, 224, **240**

Page 663, Right Column:

There is an inappropriate Index entry. In the lines originally printed as:

Quadrature signals, 335
recursive filters, 242
Quantization, coefficient/errors, 272-273

the center Index entry ("recursive filters") should be deleted as

Quadrature signals, 335
Quantization, coefficient/errors, 272-273

Page 665, Left Column:

There is a missing page number and incorrect page numbers. The lines originally printed as:

Transposed filters, 558
Transversal filter, 505, 156-631

should be corrected to:

Transposed filters, **241**, 558
Transversal filter, **155**

Page 665, Right Column:

Under the Index entry;

Windows
Kaiser, 81, 178-183

page numbers should be

Windows
Kaiser, **179-183**

Dear Reader, if you find any additional errors, no matter how trivial,
please notify me at: **R.Lyons@ieee.org**
I'd sure appreciate hearing from you and I promise I'll reply to
your E-mail.

Thanks,
[-Rick Lyons-]

